

# KIOSK



**KIOSK**  
Compartment

Introduction.....	3
Advantage of using KIOSK .....	3
Layout of KIOSK .....	4
Coupling Procedure of KIOSK .....	4
KIOSK Maintenance Guide .....	8
MV compartment.....	9
MV > Cassette Mechanism Advantages VS Conventional Roll-on truck design.....	10
Circuit Breaker Operating Instruction .....	11
MV Maintenance .....	13
Anomalies and remedies .....	17
Mechanical Interlock Chart .....	18
LV compartments .....	19
Low Voltage (LV).....	20
Maintenance of LV .....	20

## **KIOSK (Outdoor Compact Substation Enclosure)**

High voltage / low voltage (HV/LV) outdoor prefabricated (kiosk) substations have been largely used for more than thirty years, initially in Europe then gradually in other continents. Prefabricated substations are defined as an enclosure containing transformers, low voltage and high voltage switchgear, connections and auxiliary equipment to supply low voltage energy from a high voltage system or vice versa. In 1995 the first International Standard prescribing the operating conditions, characteristics, general requirements and testing methods applicable to prefabricated substations was published by the International Electrotechnical Commission (IEC) as IEC 61330. The first prefabricated substation in Australia to successfully pass a type test for personnel protection, was manufactured. This was followed by successful testing of a Ring Main Unit (RMU) outdoor enclosure in 2008. GEIS Electric continues to design prefabricated substations at the highest level of safety for the operator and the public.

## **Advantage of KIOSK**

Kiosk substations contain electrical equipment, often located in a public environment, requiring them to meet the highest safety standards. An internal arc rated kiosk substation design is manufactured to withstand the extreme pressure and force generated during an internal electrical fault. The risk of equipment failure in a kiosk substation is minimized through the design. In the rare occasions of medium voltage equipment failure, an internal arc rated kiosk design minimizes the risk of injury to nearby public or an operator working with the kiosk door open. The design ensures that extremely hot gases generated during a fault are cooled via a patented filter, reducing the effects of overpressure and flame within the enclosure. The design limits the release of projectiles and flaming particles, which could potentially injure the public, operators or start bushfires. GEIS Electric has invested in safety studies over the years to provide the safest possible solutions for our customers and general public. Environment A kiosk substation should be designed to ensure internal connections are protected from extreme environmental conditions, such as high temperatures, rainfall, dust and wind. GEIS Electric rigorous testing and graphic modelling ensures proper ventilation, protection against incoming water, sealed connections and secure locked doors. The kiosk design not only protects against the environment; it also helps to protect the environment. All our kiosk substations incorporate the option of full transformer oil containment. If the transformer leaks oil, there is no risk to the environment, as the oil is contained inside the kiosk. This feature is extremely important for applications close to water catchment areas to avoid possible pollution. At the end of the kiosk life cycle our service offer makes sure that all materials are handled with respect of environment.

## Layout of KIOSK

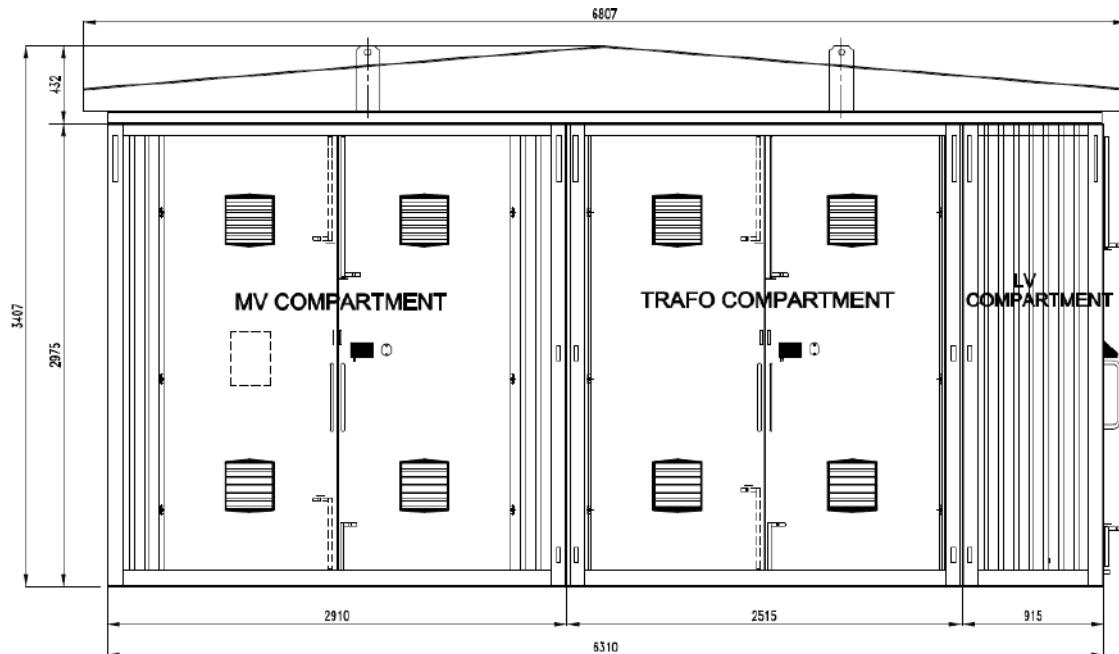

## KIOSK is comprising of three compartments

1. MV Compartment
2. Trafo compartment
3. LV compartment

## Coupling Procedure of KIOSK

1. Make sure that rating of crane/load chart is according to the weight to be lifted.
2. Ensure everyone is involved in the lift and properly briefed.
3. Ensure that professional/certified Riggers perform the lifting.
4. Close the doors of all units properly.
5. Mark the foundation surface in a way that Kiosk footing will be resting on civil foundation.
6. Make sure that sling wire is of equal length from boom hook so that each corner lift, equally.
7. Couple the shackle with lifting eye of LV unit and make sure that head of shackle pin is inward.
8. Make sure that there is no person or hurdles near the civil foundation.
9. Slowly lift the LV unit and place on the foundation according to the marked layout.



10. Apply the cementex solution on the Sealing rubber and join it on the Corners of LV unit.
11. Couple the shackle with lifting eyes of Trafo unit and make sure that head of shacklepin is inward.
12. Slowly lift the Trafo unit and place on the foundation and leave enough room to apply Sealing rubber on the corners.
13. Apply the cementex solution on the Sealing rubber and join on the Corners of trafo unit.
14. Now Lift again the Trafo Unit and aligned it with the LV unit.
15. Place shims where needed to align each corner of Trafo unit with LV unit.
16. Remove the shackles.
17. Tight the Nut and bolts and make sure that Sealing rubber are pressed against eachother and there is no gap between them.



18. Apply the ceme
19. ntex solution on the Sealing rubber and join it on the other Corners of Trafo unit.



20. Couple the shackle with lifting eyes of MV unit and make sure that head of shackle pins inward.
21. Slowly lift the MV unit and place on the foundation and leave enough room to apply Sealing rubber on the corners.



22. Apply the cementex solution on the Sealing rubber and join on the Corners of MV unit.
23. Now Lift again the MV Unit and aligned it with the LV unit.
24. Place shims where needed to align each corner of MV unit with Trafo unit.
25. Remove the shackles.
26. Tight the Nut and bolts and make sure that Sealing rubber are pressed against eachother and there is no gap between them.



27. Apply the cementex solution on the Sealing rubber and join it with the upper corners of Kiosk units.



28. Couple the shackle with lifting eyes of roof.
29. Slowly lift the Roof and place on the Kiosk.



30. Tight the nut and bolts of the roof.

### **KIOSK Maintenance Guide**

1. Regular and frequent monitoring must be done for inspecting for visual and apparent defects.
2. Removing/cleaning/washing of dust on kiosk roof and units as and when basis.
3. Repairing in the area where paint peel-off by painting.
4. If possible, then cathodic protection should provide for better protection against rust.
5. All the tower bolts and hinges should be lubricated once in a month.
6. Make sure that Earthing of all Kiosk's Units is done and should not be disconnected from outside body.
7. Inside inspection should be done on regular intervals.
8. All the nuts and bolts should be checked.
9. Proper sealing of all units should be checked.
10. All the filters of Louvers should be cleaned or replaced as per SE guidelines.
11. Base structure of all three units of Kiosk should be inspected on yearly basis.

## MV compartment

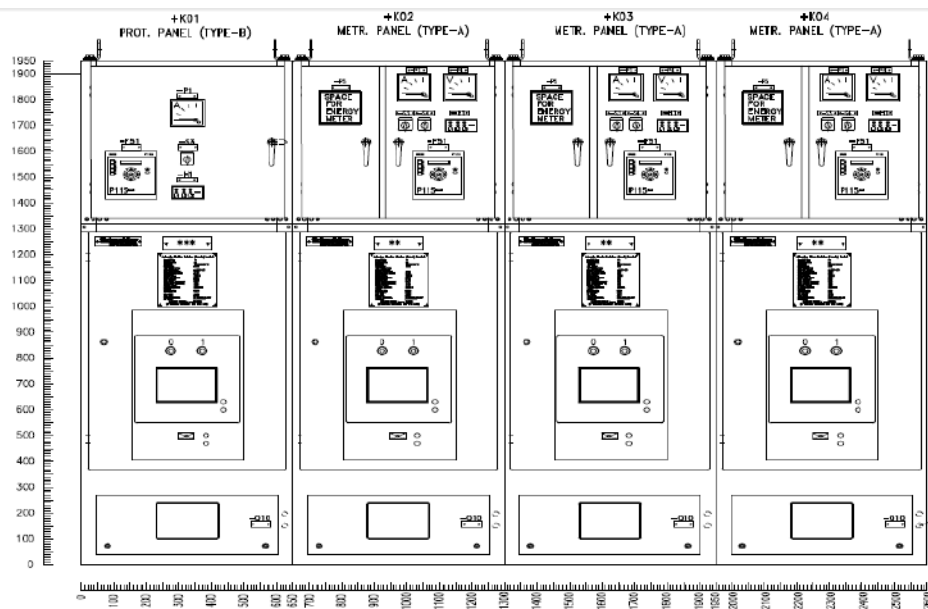

MV panel comprises of One protection MV panel and 3 metering MV panel.

MV range is an indoor switchgear assembly that provides maximum user safety. It is intended to meet all electrical distribution needs up to 24 kV and incorporates a set of innovative solutions.

It is compact in design and uses vacuum circuit breakers.

- Ratings up to 4,000 A / 40 kA for 12 kV and 17.5 kV range
- Ratings up to 2,500 A and 31.5 kA for 24 kV range
- Single and double busbar, insulated busbar
- Loss of Service Continuity - LSC 2B PM
- Floor, top or rear cable connection
- Back-to-wall or rear access configurations protocols
- Current and voltage transformers on busbar or cable side.

### Benefits of Using MV

- Space saving, flexible cubicle width and back-to-wall installation
- Safe and reliable
- Comprehensive interlocking, with all operations from the front
- Can be fully installed from the front of the cubicle
- Environmentally compatible, easy to recycle

## **MV > Cassette Mechanism Advantages VS Conventional Roll-on truck design**

- **Reduced Footprint** Reduced footprint as compared to old WKK8 design. MV (WxDxH =650x1400x1950mm), WKK8 (800x1600x1950mm) .
- **Less stringent requirement of floor level accuracy** Guide rail driven cassette mechanism makes the VCB less dependent on floor level accuracy which allows smooth rack-in and rack-out operation of VCB. Also the proper alignment of male and female contacts is ensured due to reduced implication of floor level.
- **Rigid and robust structure** An additional rail base plate fitted in the middle of the front module to support the load of the cassette mounted VCB ensures extra rigidity and stability of the overall structure.
- **Enhanced personnel safety.** Additional Door interlocks incorporated for enhanced personnel safety. All VCB operations only with closed doors.

## Circuit Breaker Operating Instruction

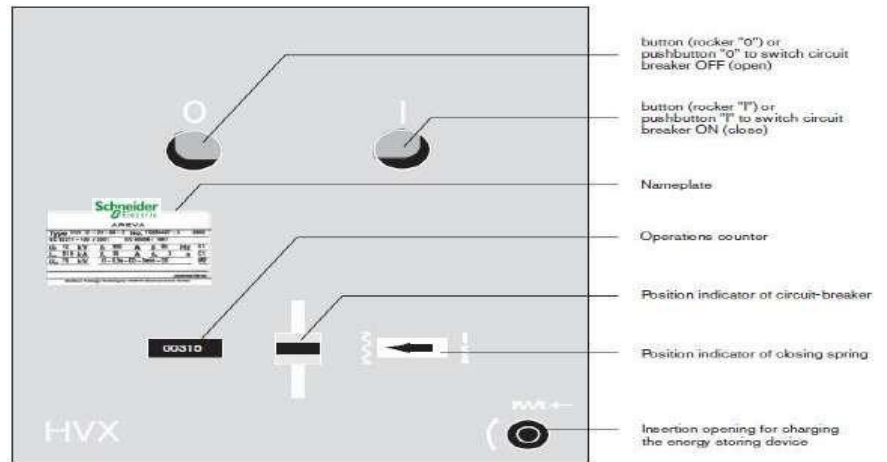
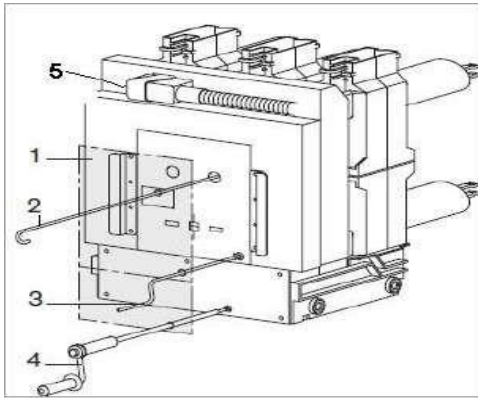

- 1 closed door of the panel
- 2 ON/OFF operating rod
- 3 Spring Charging Handle for spring operating mechanism
- 4 Racking Handle (only in case of HVX-E)
- 5 LV Control Plug

### **MECHANICAL INTERLOCKS must be checked before CB operation:**

- CB door key will remain ENGAGED when the DOOR IS OPEN & will be RELEASED only when the DOOR is CLOSED/LOCKED.
- CB cannot be moved from TEST to SERVICE position unless CB COMPARTMENT DOOR is in closed position.
- CB cannot be moved into SERVICE position unless the LV CONTROL PLUG **(5)** is inserted & locked.
- CB cannot be moved into SERVICE position while the EARTHING SWITCH is in 'ON' position.
- CB cannot be moved to SERVICE / DISCONNECTED (TEST) position while it is switched 'ON'.
- CB cannot be switched 'ON' unless it is completely set to its SERVICE / DISCONNECTED (TEST) position and the RACKING HANDLE has been removed.

### **Moving of CB from DISCONNECTED (TEST) into SERVICE position (By hand)**

1. Ensure that CB is in 'OFF' position.
2. Ensure that EARTHING SWITCH (if equipped) is in 'OFF' position.
3. Insert RACKING HANDLE **(4)** with integrated slip coupling & turn it clockwise until it produces a 'CLICK' sound and its movement STOPS. (The CB is racked into its Service Position)
4. Remove RACKING HANDLE **(4)**.

## Charging the ENERGY STORING DEVICE (Manually)

1. Insert CHARGING HANDLE **(3)** into opening for tensioning the energy storing device.
2. Charge the spring using the CHARGING HANDLE **(3)**. As soon as the spring is charged in a clockwise direction, the spring charging mechanism is decoupled and the position indicator signals "Charged".



3. Remove the CHARGING HANDLE **(3)**. The CB is ready for Closing

## Charging the ENERGY STORING DEVICE (via Motor)

1. The energy storing device of motorized CB is charged automatically as soon as the supply voltage is applied.

## Closing 'ON' of CB:

2. Push Button "ON" (I) through 'ON/OFF' OPERATING ROD .
3. The POSITION INDICATOR shows the switch position "ON".

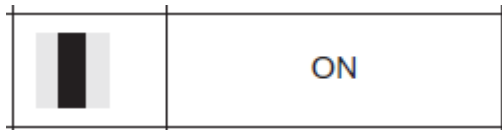

4. The energy storing device can be charged immediately after switching "ON" (by hand or motor). If voltage is applied to the motor, spring charging is performed automatically.

## Opening 'OFF' of CB:

1. Push Button "OFF" (0) through 'ON/OFF' OPERATING ROD **(2)** or actuate opening release electrically by UNDER VOLTAGE RELEASE or through SECONDARY COILS.
2. The POSITION INDICATOR shows the switch position "OFF".



## MV Maintenance

Maintenance						
<b>Levels of maintenance</b>						
Definition	Levels					
Operation recommended in the instructions manual "installation - operation - maintenance", carried out by suitably qualified personal having received training allowing them to intervene whilst respecting the safety rules.	1					
Complex operations requiring expertise and the implementation of support equipment in accordance with GEIS Electric procedures. These are carried out by GEIS or by a specialized technician, trained by GEIS Electric the implementation of procedures, and who is equipped with specific equipments.	2					
All the preventive and corrective maintenance, all renovation and reconstruction work is carried out by GEIS Electric	3					
<b>Preventive maintenance of the moving parts</b>						
PREVENTIVE MAINTENANCE	Frequency			Levels		
Recommended Operations	03 Month	06 Month	Year	1	2	3
Removal of dust from the insulating enclosure of the poles (clean, dry cloth)			X	X	X	X
Checking the state of the plugging-in clamps			X			X
Checking the removing part's of earthing switch device (clamps and contact jaws)		X	X			X
<b>Preventive maintenance of the functional units</b>						
PREVENTIVE MAINTENANCE	Frequency			Levels		
Operations recommended at the functional unit level	03 Month	06 Month	Year	1	2	3
Verification of the presence and condition of accessories (levers, etc)			X	X	X	X
Visual inspection of exterior appearance (cleanliness, absence of oxidation, etc)	X		X	X	X	X
Cleaning the external elements, with a clean dry cloth	X		X	X	X	X
Checking the tightness to torque (covers, wiring ducts, connections, etc)		X	X	X	X	X
Checking the mechanical controls by carrying out a few operations		X	X	X	X	X
Checking the positioning the status indicators (open and closed)			X	X	X	X
Control of the status and the functioning of the mechanical locking by key locks			X	X	X	X
Dusting and cleaning the internal mechanical elements (without solvents)	X	X	X		X	X
Inspection of the tightening of the threaded fasteners and presence of			X		X	X

internal stops						
Dusting and cleaning the internal mechanical elements (with solvent)	<b>X</b>	<b>X</b>	<b>X</b>			<b>X</b>
Lubrication and greasing of mechanical elements (with recommended products)		<b>X</b>	<b>X</b>			<b>X</b>
Monitoring the general appearance of the mechanical components and connections		<b>X</b>	<b>X</b>			<b>X</b>
Testing the "function" mechanical interlocks			<b>X</b>			<b>X</b>

<b>PREVENTIVE MAINTENANCE</b>				<b>Frequency</b>			<b>Levels</b>		
<b>Operations that are specific to the "moving part" compartments</b>				<b>03 Mont h</b>	<b>06 Mont h</b>	<b>Yea r</b>	<b>1</b>	<b>2</b>	<b>3</b>
Ensure the smooth functioning of the shutters (plugging-in/withdrawing)				X	X	X		X	X
Checking the state of the plugging-in electrodes						X			X
Cleaning of the insulating elements, with a clean dry cloth				X	X	X			X
Cleaning and lubricating the mechanical parts				X	X	X			X
Examination of the electrical power contacts					X	X			X
<b>Operations that are specific to the bus bar compartments</b>				<b>03 Mont h</b>	<b>06 Mont h</b>	<b>Yea r</b>	<b>1</b>	<b>2</b>	<b>3</b>
Checking the tightness of the bus bar connections						X		X	X
Checking the leak tightness in the compartments						X		X	X
Cleaning the internal elements (insulators, connection, supports, etc)				X	X	X		X	X
Visual inspection of the appearance of internal components				X	X	X			X
<b>Operations that are specific to the "High Voltage Cables" compartment</b>				<b>03 Mont h</b>	<b>06 Mont h</b>	<b>Yea r</b>	<b>1</b>	<b>2</b>	<b>3</b>
Checking the state of the earthing switch contacts						X			X
Checking the leak tightness in the compartments						X			X
Examination of the state of the cable reassemblies						X			X
Cleaning the internal elements (insulators, connection, supports, etc)				X	X	X			X
Cleaning and lubricating the mechanical parts				X	X	X			X
Visual inspection of the appearance of the internal components				X	X	X			X
<b>Operations specific to the Low Voltage box</b>				<b>03 Mont h</b>	<b>06 Mont h</b>	<b>Yea r</b>	<b>1</b>	<b>2</b>	<b>3</b>
Checking the state of the internal components					X	X		X	X
Checking the tightness to torque of the terminals and electrical connection in general						X		X	X
Examination of the general state of the wiring and the relays & other electrical components						X		X	X
<b>Operations specific to the battery charger &amp; battery box</b>				<b>03 Mont h</b>	<b>06 Mont h</b>	<b>Yea r</b>	<b>1</b>	<b>2</b>	<b>3</b>
Visual inspection of battery charger components and batteries				X	X	X			X
Checking the tightness of the terminal and components wiring						X			X
Cleaning the terminal and components					X	X			X
<b>Operations specific to the LV panel</b>				<b>03 Mont h</b>	<b>06 Mont h</b>	<b>Yea r</b>	<b>1</b>	<b>2</b>	<b>3</b>
Checking the state of the internal components					X	X		X	X
Checking the tightness to torque of the terminals and electrical connection in general						X		X	X

Examination of the general state of the wiring and the relays & other electrical components			x		x	x
Cleaning the internal components	x	x	x			x

## Auxiliary Products

The auxiliary products are available from the manufacturer. The use of alternative auxiliary products is not permissible.

### Warning!

**Risk of injury in case of inappropriate handling.**

Auxiliary products	Item no.	
Cleaning agent	S 008 152	
Lubricant KL, 0.5 kg can	ST 312-111-835	
Liquid lubricant FL, 0.5 kg can	S 008 153	
Repair paint, 500 g can, RAL 7032	S 009 492	

### Treatment of firmly screw-connected contact surface

#### Important:

Caution when handling bars insulated by heat-shrinkable sleeves: The heat-shrinkable sleeve must not get into contact with lubricant (swelling).

Contact areas coated with lubricant KL should not be touched, if possible.

- Contact areas must be subjected to preliminary treatment before screw fastening.
- Immediately after the preliminary treatment, coat contact surfaces completely with a thin and uniform film of lubricant KL.

## Lubrication

Points of lubrication	Lubricant	Lubrication Procedure
Sliding contact surfaces	KL	Cleaning by means of lint-free cloth; use cleaning agent in case of serious contamination. Apply a thin and uniform film of lubricant.
All accessible friction points and sliding surface	KL	cleaning lubricating points using a lint-free cloth or a soft paint-brush, if necessary using cleaning agent (use sparingly, just moisten points of lubrication). Apply a thin coat of lubricant (using e.g. a paintbrush).
Bearing and joints	FL	Pour drops of liquid lubricant (oil can, drip feed lubricator) into the bearing gap. Liquid lubricant gets between the bearing surface due to the capillary effect. In case of inaccessible lubrication points, use an extension tube or spray.

1. Clean by means of lint-free cloth; use cleaning agent in case of serious contamination (See above)
2. Expose Metallic surface
  - by treating the entire surface with emery cloth or a rotating grinding tool (grain size 100 or 80) or
  - using a wire brush which is clearly marked for use exclusively for aluminum or exclusively for copper
3. using a brass brush, steel brush
4. rub slightly by hand using scotch brite abrasive agent (Ni layer must not be reduced)

## Anomalies and remedies

Observation	Mechanism	Probable cause	Remedy
■ Unusual noises when energized, crackling, vibrations.	■ Voltage presence box	■ "Faston" plug poorly	■ Check the connections
	■ Capacitive voltage divider	■ Defective voltage divider	■ Replace the defective capacitive voltage divider
	■ Insulators	■ Polluted or degraded insulating parts	■ Clean the parts or consult our After-Sales Service: see address at the beginning of the manual
■ Abnormal overheating at the connecting points.	■ Connecting	■ Poor tightening	■ Retighten to the appropriate torque after cleaning the contact plates
■ Voltage presence indicator extinguished.	■ MV fuse on outgoing switch or contactor	■ Fuse blown	■ Replace all three fuses
	■ Voltage presence box	■ Deterioration of a component	■ Replace the box
■ Abnormal efforts for mechanical parts operations.	■ Earthing switch	■ Safety interlocking.	■ Check the position of the control mechanisms
	■ Plugging-in of the circuit breaker or contactor moving parts		
■ Circuit breaker does not close.	■ Line section switch or LV circuit breaker	■ Line section switch or LV circuit breaker open	■ Check the closure of the switch or the LV circuit breaker
	■ Protection devices	■ Action by protection devices	■ Check the adjustments
	■ External connections	■ Poor connection.	■ Check wiring diagrams
	■ Low voltage connector of the circuit breaker	■ Poor connection	■ Check the connection

## Mechanical Interlock Chart

Interlock	Function of interlock	Method of operation of interlock
Between truck and low-voltage connector	The truck cannot be actuated unless the low-voltage connector is inserted	The opening for the moving crank handle is locked
Between truck and earthing switch	The truck cannot be moved into service position while the earthing switch of the switchgear panel is in "ON" position	The moving crank handle is uncoupled automatically.
	The earthing switch cannot be switched on once the truck has left its disconnected position.	The rotary movement of the earthing switch lever is blocked. Do not apply force!
Between the cable compartment cover and the earthing switch (optional)	The cable compartment cover can only be removed if the earthing switch is ON.	The cable compartment cover is locked mechanically by means of a sheet metal plate.
Between the truck and the switching device compartment cover (optional)	The switching device compartment cover can only be opened if the truck is in its disconnected position.	The switching device compartment cover cannot be lifted via the opening handle unless the truck is in disconnected position.
	If the switching device compartment cover is opened, the truck cannot be moved into service position.	The crank of the truck cannot be inserted if the switching device compartment cover is open.
Between truck and operating state of the vacuum contactor	The truck cannot be racked in or out while the vacuum contactor is switched on.	The opening for the moving crank handle is locked.
	The vacuum contactor cannot be switched on unless <ul style="list-style-type: none"> <li>■ it has completely reached its disconnected or service position and</li> <li>■ the operating crank for the rack-in mechanism has been removed</li> </ul>	The vacuum contactor cannot be switched on or off.

## LV compartments

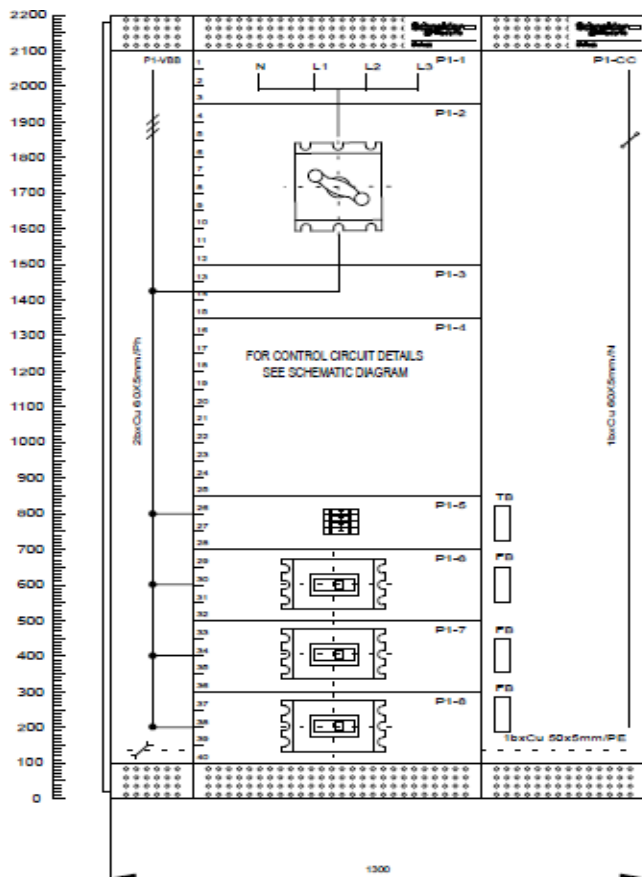
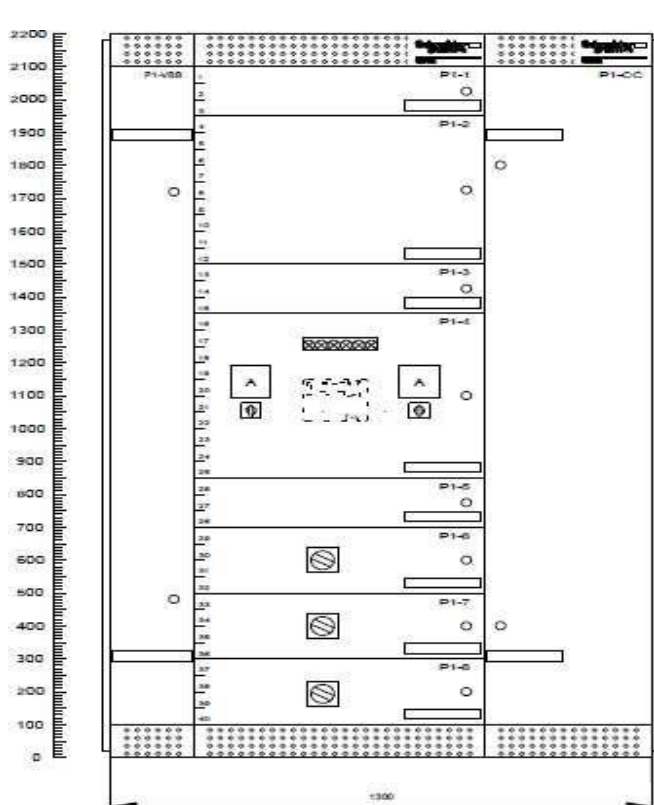

## Low Voltage (LV)

LV switchboards have long guaranteed the durability and availability of several tens of thousands of installations the world over. Tried and tested reliability, overall performance and an attractive TCO (Total Cost of Ownership) have caused LV to become, the reference switchboard for a large number of panel-builders, industrial site managers and maintenance managers, in a few years.

## Maintenance of LV

Common maintenance operations for the entire range.

- Check inside and outside the switchboard for moisture or foreign material.
- Remove any foreign material and clean the switchboard.
- Use a vacuum cleaner to clean. If necessary, clean the ventilation system and change the filters.
- Clean old grease off all mechanical parts and regrease lightly .
- Examine the outer finish of the switchboard. If necessary, touch up any paint
- Scratches and replace any damaged or rusted parts.
- Check the insulation monitoring devices.
- Run tests on the indication systems.
- Visually check the busbars:
  - Assembly screws for busbars do not need to be tightened as long as the varnish, guaranteeing correct tightening torque, is intact;
  - The check on busbar connections is, therefore, strictly visual to detect any hot points (change in colour).
  - If a hot point is detected, the assembly must be dismantled. Clean and sand the contact surfaces (sand paper grade 400). When remounting:
    - use identical (class 8.8) new hardware (bolts, nuts and washers);
    - tighten as indicated in the table below;
    - Apply varnish.
- Visually check the condition and tightness of the busbar supports.
- Check the tightness of customer cables.
- Run a check on the switchgear devices.
- Consult the corresponding manuals.

### Table indicating tightening torques

The table below indicates the correct tightening torque for class 8.8 hardware with nuts and contact washers.

Diameter of bolt	Tightening torque (m.daN) nut with contact washer
HM3	0.15
HM4	0.35
HM5	0.70
HM6	1.3
HM8	2.8
HM10	5
HM12	7.5
HM14	12
HM16	18.5
HM18	26
HM20	37